



# PRO FLAPS

## CUSTOM MUD FLAPS

# #430

## 2.5" KickBack Mud Flaps

1973 - Current Model Rear Mounted

### PACKAGE CONTENTS:

- 16 - 1" x 1/4" Bolts
- 32 - 1/4" Washers
- 16 - 1/4" Nylock Nuts
- 2 - KickBack Brackets
- 2 - Pro Flap Mud Flaps
- 2 - Support Brackets

**Pro Flaps does not come attached to the KickBack Bracket so you can shorten down the flap material to customize the length.**

### RECOMMENDED TOOLS:

- Power Drill with 1/4" Drill Bit
- 7/16" Socket/Driver
- 7/16" Wrench

**Read all direction thoroughly before installation of your new Pro Flaps KickBack Mud Flaps. Make sure to park your vehicle on a level surface and clean fender mounting area prior to installation. Your Pro Flaps a designated Driver side and Passenger side. The Small angle cut on the bracket goes to the outside and the 5/8" solid bar on the ridged side of your Pro Flaps goes to the outside edge of the brackets. Pro Flaps must have a minimum clearance of 4" from exhaust pipe on gas engines and 7" on diesel engines. Any muffler shop can easily heat and bend exhaust pipe.**

- 1. For best mounting locate factory holes and use them whenever possible. Start by placing your KickBack Bracket into the fender and checking to see which of the factory hole will work for your truck. Than remove and screws/bolts. Drill out the factory holes with the 1/4" drill bit and drill any additional holes as needed. We recommend 3 bolts per bracket for best hold into the fender.**

**Pro Flaps Mud Flaps need to be mounted to the metal portion of your fender to prevent damage to your truck.**

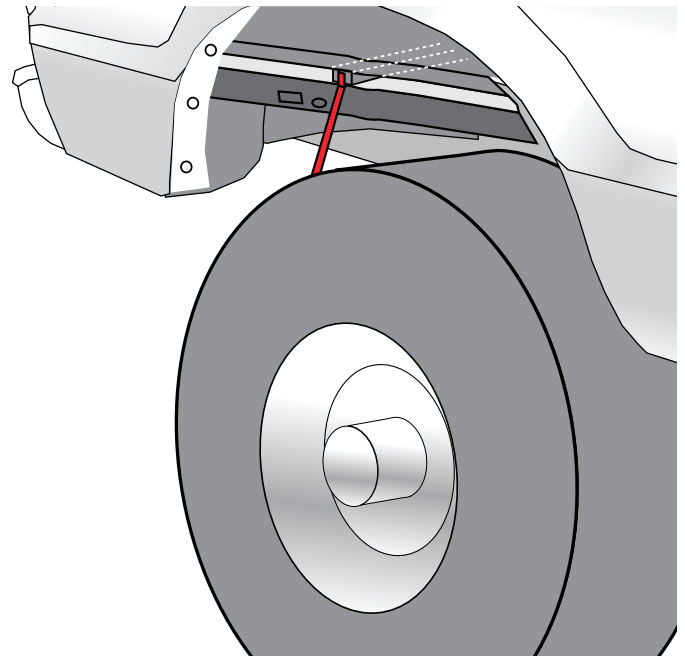

2. To transfer holes to your KickBack Bracket take a piece of chalk and rub it around the edge of each hole.

**If you don't have chalk use something that will leave a mark on the bracket like play-dough or even chewing gum.**

3. Align the outside edge of your KickBack Bracket to the outside edge of your tire.

**You can mount your Mud Flaps in many different ways but mounting to the outside edge of your tire will give you maximum coverage.**

**Make sure the bottom portion of your KickBack Bracket is parallel to the ground and pressed tightly to the bottom on the fender. Press it firmly against the fender to transfer chalk to your KickBack Bracket.**

4. Remove KickBack Bracket from fender and using your 1/4" drill bit drill out your holes.
5. Install your KickBack Bracket to your fender using 3 of the 1" bolts, 6 washers and 3 nylock nuts.
6. Measure the Mud Flap and cut it down to desired height as needed before installing it on your KickBack Bracket. Make sure to re drill the holes with your 1/4" drill bit to top of Mud Flap and install onto your KickBack Bracket.

**Do not have your Pro Flap Mud Flaps mounted any closer than 7" to the ground.**

7. Use the support brackets included with your 430 KickBack Mud Flaps to add support. These are optional but we do recommend them to help pull the KickBack Bracket straight and add support. Install one end of the support bracket to the back inside of the existing bolts used to mount your Pro Flap Mud Flap and attach the other end to either the body or frame of your vehicle. Use and existing hole if possible.

