

# PRO FLAPS

OVER SIZE TIRES  
INSTALLATION FOR FRONT & REAR

## FORD CHEVY DODGE

1. Your PRO-FLAPS are designated left (driver's side) and right (passenger side). There is a 5/8" solid bar down the outside edge of the flap material.

2. Mark and drill 3/16" hole in back edge of fender- Secure Flap using 1" bolt, washer and nylock on fender wall.

3. Align support bracket to flap attach to under bed brace. Attach other end of bracket to Pro Flap using 1" bolt, washer and nylock.

(PRO-FLAPS ) must have a minimum clearance from tires and exhaust pipes of 4 inches, on diesel engines, tail pipe must be 7", Damage to flap will occur if closer!

TIP: Any muffler shop can easily heat and bend exhaust pipe.

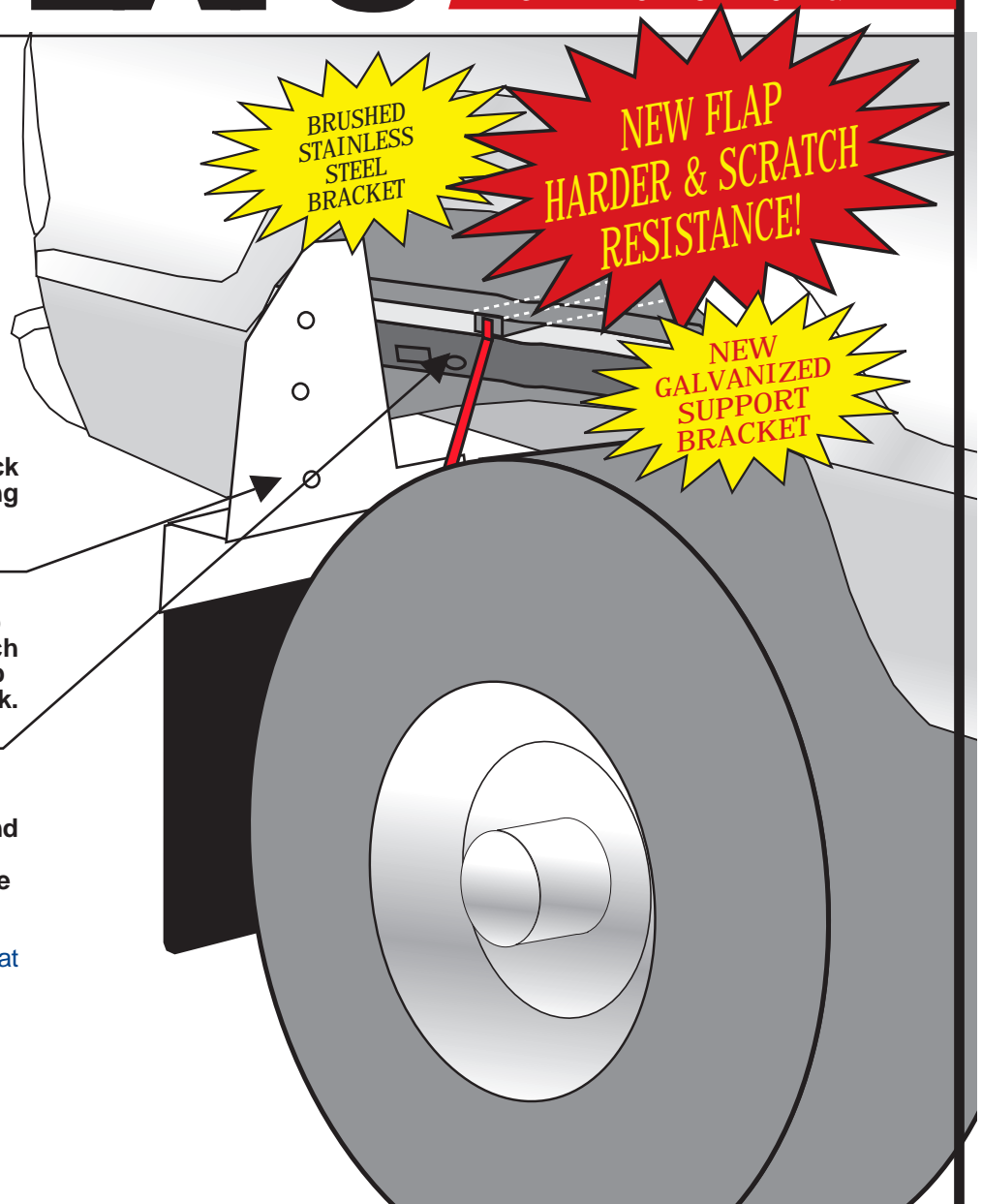

The feature that makes PRO-FLAPS a NEW and exciting product line is the quality that is built into the Flap from the HEAVY DUTY 3/8 BLACK POLYURETHANE (no regrind) Anti-Spray Design, Groved on the tire side to Direct the Spray down, not out!

### INSTALLATION:PARTS INCLUDED: 1.

1. 10 -1"bolts
2. 26 washers
3. Two support brackets
4. 6 Round Bolts 1 "
5. One set of PRO-FLAPS
6. 16 Nylock Nuts

### TOOLS REQUIRED:

- A. Phillips screw driver
- B. Drill motor
- C. 3/16" drill bit - screws
- D. Pliers
- F. 1/4" drill bit - bolts

Contact your F.R.U./PRO FLAPS Dealer  
Or F.R.U. at 260 E. Pomona Rd., Yakima, WA 98901  
Phone: (509) 453-4318 • Fax: (509) 249-8570

©2004 FRU All right reserved.